

Fan Inlet Airflow Measurement Systems

System Features

- Mount directly in the inlet of centrifugal or vane axial fans.
- Adjustable mounting brackets simplifies ordering and installation.
- Each sensor is factory calibrated to NIST traceable airflow and temperature standards.
- Accurate and repeatable measurement from still air (0 ft./min.).
- True average, independent multi-point sensing.
- Advanced Thermal Dispersion (TD) airflow measurement technology.
- Sensor and transmitter diagnostics with intelligent sensor detection system.
- Stable, hermetically sealed "bead in glass" thermistor sensors.
- Exclusive "plug and play" SMART sensor design.
- Microprocessor based digital circuitry with FLASH memory.
- Fully temperature compensated.
- Provides direct signal(s) to all B.A.S.
- Very competitively priced.

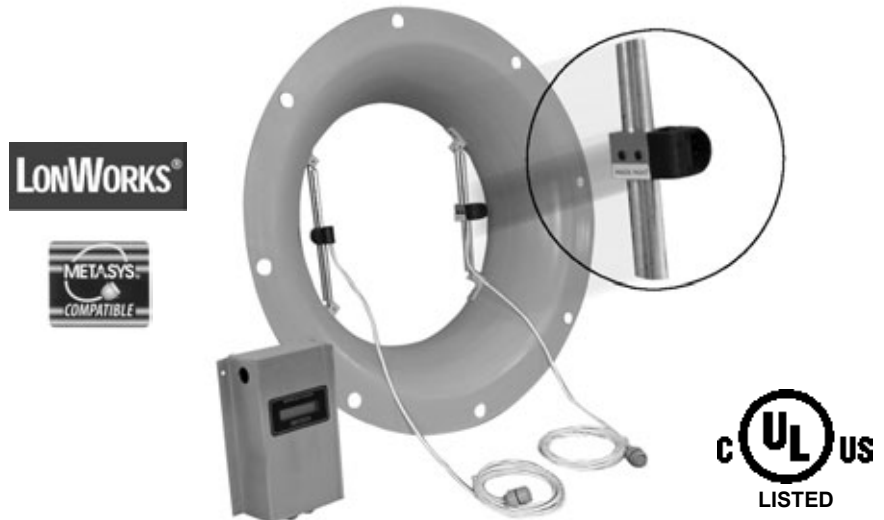

Single centrifugal fan Installation shown. Inlet bell for illustration only

Application

Thermal dispersion technology can accurately determine airflow rates directly in the inlet of centrifugal or vane axial fans.

The **GTx116-F** is ideal for volumetric fan tracking and space pressure control where linearity and repeatability are essential to system performance.

For detailed application information refer to **EBTRON** application design guides, available in your **EBTRON** catalog, online at ebtron.com or from your local **EBTRON Representative**.

Selection

The **GTx116-F** has been developed with most "traditional" options included standard. Each transmitter serves a single fan location and can be configured for both single and dual inlet fans. The transmitter requires 24 VAC and provides the host controls with linear analog output signals for airflow and temperature (**consult the GTx116 Transmitter Installation & Configuration Guide** for RS-485, Ethernet and LonWorks options).

Each transmitter is fully independent of the sensor probes. "Smart" sensor technology embeds the calibration data of each sensor in the probe cable assembly. The **GTA116** transmitter is provided with field selectable, isolated 4-20 mA and 0-10 VDC analog output signals for airflow and temperature. Output scales can be configured easily in the field (see product specifications for factory default settings). Each transmitter is provided with "digital potentiometers" for airflow signal offset and gain adjustment.

Six different sizes are available to accommodate fans with inlet diameters between 11" and 64". Adjustable mounting brackets simplifies ordering and installation. The model **GTx116-F** has a typical installed accuracy between 3% and 10% of reading when installed in accordance with **EBTRON** installation guides without any field adjustment (see: **Locating Probes**). Installed accuracy is primarily a function of the inlet area calculation and presence of disturbances near the fan inlet (i.e. belt guards, pulleys, bearings, etc.). An installed accuracy of $\pm(2\%$ to $3\%)$ of reading can be obtained with field adjustment when the recommended setup procedures are followed (see: **EBTRON Application Notes** for specific recommendations).

EBTRON
Thermal Dispersion Airflow Measurement

1663 Hwy. 701 S., Loris, SC 29569 USA
Toll Free: 800-2EBTRON (232.8766) Fax: 843.756.1838
Internet: www.ebtron.com e-mail: ebtron@ebtron.com

Locating Probes

Mount the sensor probes parallel to each other in the fan inlet. Avoid mounting the sensor directly behind an obstruction.

Centrifugal Fans

Locate the sensor probes in the narrowest portion of the inlet cone as indicated below for the most reliable performance.

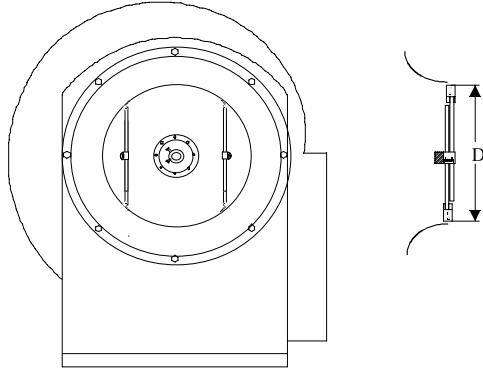

Vane Axial Fans

Locate the sensor probes upstream of the fan blades as illustrated below.

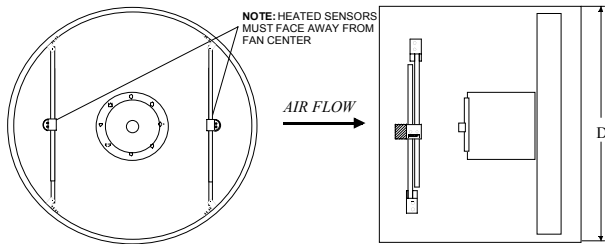

Probe and Sensor Density

The GTx116-F is available for either single or dual inlet fan configurations. Each inlet is provided with two sensor probes. Probes are ordered using the nominal inlet diameter where the device will be mounted. Inlet probes are manufactured in six standard sizes that have adjustable mounting brackets to simplify installation. The table below indicates the range of inlet diameters that each standard size can accommodate.

Inlet Sizes for Standard Mounting Brackets

Standard Size Code	Inlet Diameter	
	is greater than or equal to	and is less than
1	11	14
2	14	17
3	17	29
4	29	43
5	43	57
6	57	64

Probe Installation

Fan inlet sensors are designed to be mounted in the throat of centrifugal fans or the housing of a vane axial fan upstream of the blades. Adjustable mounting brackets allow for precise sizing at the job site. Make sure that no moving parts can interfere with the sensor assemblies, mounting hardware, or wiring. All probes have a standard 10 foot plenum rated cable (optionally up to 50 feet) for connection to the remotely located transmitter (required). Each Sensor probe is connected to the transmitter with a simple, positive locking, plastic connector. The connector is 7/8" O.D. The length of the cable is measured from the end of the sensor probe and is the same length for each probe in a given location.



The cable length ordered must be long enough to accommodate the distance between the transmitter and furthest sensor probe.

Measure the diameter, "D", of the fan at the location that you intend to mount the flow station. Look up the dimension for "L" from table below based on the inlet diameter "D" that you measured. Set each rod length, based on table measurements. The length given in the table is the distance between the center set screws of the sensor housing and roll pin in the sensor mounting foot. Set the length of each rod and securely tighten the sensor housing set screws. Be certain that the mounting feet orientation is correct with respect to the sensor housing.

Determination of length "L" for Mounting Bracket Adjustment

Inlet Diameter "D"	L	Inlet Diameter "D"	L	Inlet Diameter "D"	L
11	3 11/16	29	11 1/4	47	18 7/8
12	4 1/8	30	11 11/16	48	19 1/4
13	4 9/16	31	12 1/8	49	19 11/16
14	4 15/16	32	12 1/2	50	20 1/8
15	5 3/8	33	12 15/16	51	20 1/2
16	5 13/16	34	13 3/8	52	20 15/16
17	6 1/4	35	13 13/16	53	21 3/8
18	6 5/8	36	14 3/16	54	21 13/16
19	7 1/16	37	14 5/8	55	22 3/16
20	7 1/2	38	15 1/16	56	22 5/8
21	7 7/8	39	15 1/2	57	23 1/16
22	8 5/16	40	15 7/8	58	23 8/16
23	8 12/16	41	16 5/16	59	23 7/8
24	9 3/16	42	16 3/4	60	24 5/16
25	9 9/16	43	17 3/16	61	24 3/4
26	10	44	17 9/16	62	25 3/16
27	10 7/16	45	18	63	25 9/16
28	10 7/8	46	18 7/16	64	26

L = distance between locking set screw at sensor housing and mounting foot roll pin

Fan Inlet Sensor Probe Assembly

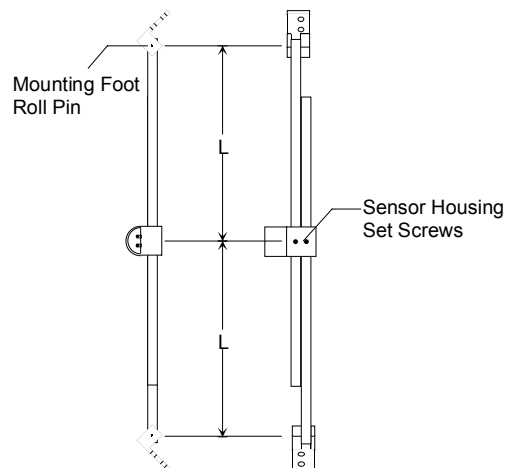

Mount one pair of fan inlet sensors in each fan inlet with hardware suitable for inlet conditions and that will not interfere with the fan during operation. The thermistor sensor probes should face the inlet cone. After installing the first sensor assembly in an inlet, position the second sensor assembly, as close as parallel to the first sensor assembly as possible, on the opposite side of the inlet. Secure the cable to the sensor assembly rods with tie wraps and secure to the inlet housing with cable clamps.

Transmitter Installation

The **GTx116-F** transmitter aluminum chassis has been designed for use in a protected environment between -20°F and 120°F where it will not be exposed to rain or snow.

The transmitter should be mounted **upright** in a field accessible location. The chassis is designed to accept 3/4" conduit fittings for power and signal wiring at the top left and right of the enclosure. The transmitter should be located such that the connecting cables from all of the sensor probes reach the receptacles on the bottom of the transmitter enclosure.

 Do not expose the transmitter to rain or snow without providing a NEMA4 enclosure.

Transmitter Dimensions

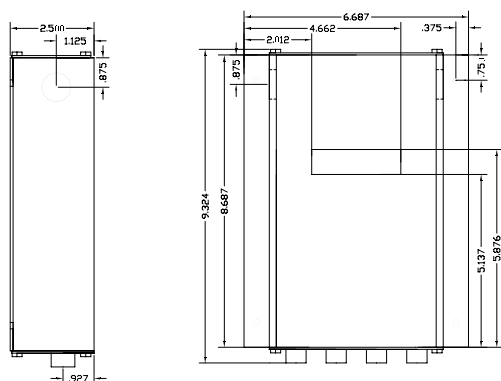

Electrical Connections

After mounting the sensor probes and transmitter, connect the sensor probe cable plugs to the circular receptacles located at the bottom of the **GTx116-F** transmitter enclosure. Probes are "plug and play" and do not have to be connected to a specific receptacle on the transmitter. All **GTx116-F** transmitter enclosures have 4 receptacles. Plug sensor probes into any open receptacle for proper operation.

 Do not drill into the transmitter chassis since metal shavings could damage the electronics.

To wire the output signal and power, slide the cover plate up and out of the extruded chassis. Make sure that the power switch is in the "OFF" position. The **GTA116** wiring schematic is shown above. **Wiring and setup for network transmitters can be found in the the *GTx116 Transmitter Installation & Configuration Guide* for RS-485, Ethernet and LonWorks options.** Signal wires for airflow and temperature should be connected to the small, three position output terminal labeled "OUTPUT" on the upper left hand side of the main circuit board.

 When configured for a 4-20 mA output, the **GTA116-F** is "4-wire" device. The host controls should not provide an excitation voltage to the output of the **GTA116-F**.

24 VAC power should be connected to the large, two position power input terminal labeled "POWER" on the upper right hand side of the main circuit board. Since the output signals are isolated from the power supply, it is not necessary to provide an isolated (secondary not grounded) power source.

 Multiple **GTx116** transmitters wired on a single transformer must be wired "in-phase".

Transmitter Wiring and Circuit Board Functions (GTA116 Transmitter Shown)

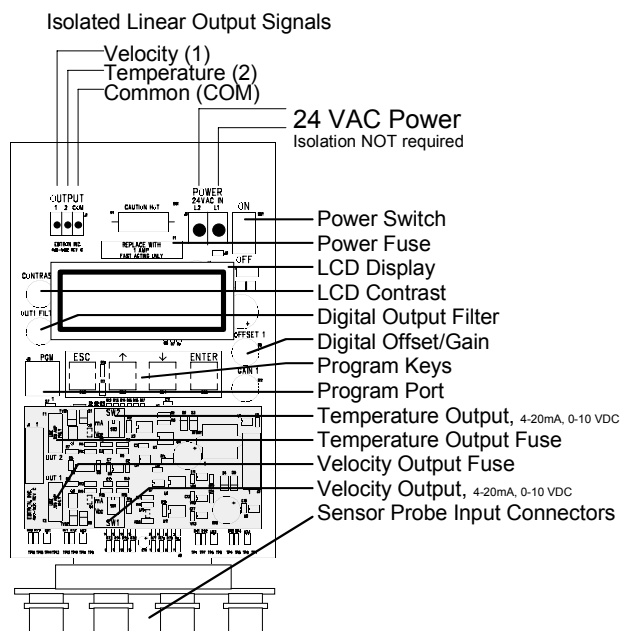

Start-up

To assure a successful startup, check that the airflow measuring station is installed in accordance with this document.

 Check the physical installation, power connections, and signal wiring prior to turning the power switch to the "ON" position.

The **GTA116** transmitter is factory shipped with the analog output signals set to the 4-20mA default. If a 0-10 VDC output is desired, simply move the corresponding switch (SW1 for velocity, SW2 for temperature) to the 0-10 VDC position prior to power-up. To convert to CFM simply multiply the full scale velocity output by the free area, in square feet, based on the diameter measured across the leading edges of the sensor probes. Subtract the area of obstructions in the fan inlet from the free area.

Move the power switch to the "ON" position. The transmitter executes a complete self-check each time the power is turned on. Check that scaling in the host control system returns an output that matches the output of the **GTx116**.

The **GTx116** is designed to operate on "power-up". No field configuration is required. If factory default settings require a change in the field, consult the **GTx116 Transmitter Installation and Program Guide** or contact **EBTRON** Customer Service, toll free, at 800-232-8766.

Maintenance

In most HVAC environments, periodic maintenance or recalibration is neither required nor recommended¹.

¹In extremely dirty environments, periodic inspection of the sensor element is advised. Carefully remove any excessive buildup of material with compressed air or with a small brush. Recalibration is not required.

Standard Limited Warranty

If the **GTx116-F** fails within 36 Months from Shipment, **EBTRON** will repair/replace the device free of charge as described in the company's warranty contained in **EBTRON's Terms and Conditions of Sale**. Defective equipment shall be shipped back to **EBTRON**, freight pre-paid, for analysis.

Model GTx116-F Technical Specifications

System Performance

GTA116-F Installed Airflow Accuracy (typ. ± of reading):

3% to 10%

Repeatability (± of reading): 0.25%

Measurement Units: I.P. or S.I. (consult separate S.I. unit supplement for settings and factory defaults)

Sensor Probe Specifications

Sensor Assembly Model: GF1

Construction: 304 Stainless steel sensor assembly housing with 304 stainless steel mounting feet.

Sensor Assembly: Two hermetically sealed "bead-in-glass" thermistors in a glass filled polypropylene housing

Fan Inlet Size Range: 11" to 64"

Cable Assembly:

Type: Plenum Rated

Length: 10' std. (50' opt.)

Connection to Transmitter: 7/8" Positive lock w/gold plated contacts

Number of Air Velocity Calibration Points: 16

Number of Temperature Calibration Points: 3

Maximum Number per Fan Inlet: 2

Airflow Sensor Accuracy (± of reading): 2%

Calibrated Range: 0-10,000 FPM

Temperature Sensor Accuracy: ± 0.15° F

Sensor Temperature Range: -20° F to 120° F

Humidity range: 0 to 99% RH, non-condensing

Transmitter Specifications

Transmitter Model: GTx116

Maximum Number of GF1 Sensors per Fan: 4

Microprocessor: Powered by Motorola® Digital DNA™

A/D Converter: 12 bit

Sensor Independent Electronics: Yes

Power Requirement: 24 VAC (22.5 to 29 VAC), 10 VA max. (fused and protected on transmitter, isolation not required)

Chassis (enclosure): Aluminum (protect from water and condensation)

Output Signal Adjustments: Field adjustable digital airflow output offset/gain

Output Signal Filtering: Field adjustable digital airflow output filter

Display: 16 character LCD display with field selectable output

Airflow: FPM, CFM w/area input

Temperature: ° F

Display Digits (auto-ranging with units of measure):

Airflow: 0.00 to 999.99, 1000.0 to 9999.9, 10000 to 999999

Temperature: -99.9 to -0.1, 0.00 to 99.99, 100.0 to 999.9

Analog Output Configuration (GTA116 Transmitter)

Analog Output Protection: Fused and protected ISOLATED analog outputs

Analog Output Signals: Field selectable, linear analog output signals of 4-20mA and 0-10 VDC for airflow and temperature

Airflow Analog Output Scaling (0 to selected F.S.): Field selectable from 100 to 15,000 FPM, 100 FPM increments

Factory Default: 10,000 FPM

Temperature Analog Output Scaling (Min.S. to F.S.): Field selectable from -50° F to 160° F F.S. > M.S. + 10° F

Factory Default: -20° F to 160° F

Analog Output Resolution (full scale output): 0.025%

Network Output Configurations

GTN116 Transmitter: 9600 baud RS485 Serial, JCI N2-Bus, ModBus-RTU

GTE116 Transmitter: Ethernet 10 BaseT, TCP/IP, ModBus-TCP

GTL116 Transmitter: LonWorks Free Topology

Transmitter Temperature Range: -20° F to 120° F

Warranty

Standard Warranty: 36 Months from shipment

Underlined items indicate *Factory Default* settings.



Metasys and Metasys Compatible Product are Trademarks of Johnson Controls.

Applies to GTN116-P only.