



AIRFLOW MEASURING STATION KMS SERIES

DESCRIPTION

The **KMS Series** airflow measuring stations utilize multiple averaging sensors for total (velocity) pressure measurements and a bullet-nose probe for static pressure. The sensors are distributed across the flow stream to conform to the industry standard rules for equal-area averaging (the standard pitot traverse). The standard unit includes a 16 gauge galvanized casing with flanged duct connection, 3/8" hexagon-celled aluminum flow straightening vanes, and internal copper sensors constructed to ASTM B88. Instrument connections are 1/2" FNPT. Other configurations are available on request.

APPLICATIONS

The **KMS Series** airflow measuring stations, when utilized with a differential pressure transmitter, provide an accurate, repeatable airflow signal for building automation and HVAC applications. Air velocity may be determined by the formula: $Velocity (ft/min) = 4004 \sqrt{\Delta P}$, where ΔP is differential pressure in" W.C. Flow rate may then be determined by the formula: $CFM = A_e V$, where A_e is the effective area of the flow measuring station in square feet, and V is the velocity obtained above. The proper range for a differential pressure transmitter for use with an **KMS Series** airflow measuring station may be determined by the formula: $\Delta P = (Max\ Velocity/4004)^2$.

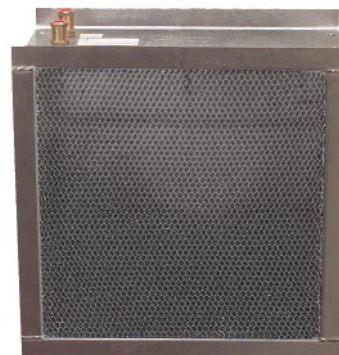

KMS Front



KMS Back

SPECIFICATIONS			
Accuracy	+/- 2% to 6000 feet per minute (+/- 0.5% at 2000 feet per minute)	Maximum design flow	6000 feet per minute
Temperature	Maximum operating, 400°F	Casing	16 gauge galvanized sheet steel, LENGTH: 12 in. overall
Pressure	Maximum operating, 6" W.C.	Pitot and static sensors	Rigid copper, hard drawn, to ANSI H23.1 and ASTM B88 standards
Pressure drop	Less than 0.13" W.C. at 2000 feet per minute with 3/8" cell	Internal fittings	Copper, to ANSI B-16.22 standards
Flow straightening vanes	3/8" aluminum hexagon cell	Process connections	1/2 in. NPT female

INSTRUMENT OR GAUGE CONNECTIONS

Connect the instrument tubing to the HI and LO station connections. The HI and LO ports are clearly labelled (HI is on the upstream side of the unit). Use two wrenches when installing the tubing fittings, taking care to hold the station fitting securely while tightening the tubing fitting. Avoid twisting the internal parts of the measuring assembly. Use thread sealer to prevent leaks, since small leaks may cause inaccuracies in measurements.

UNPACKING AND INSPECTION

Unpack the station carefully to avoid damaging the honeycomb, straightening-vane section. If any portion of the honeycomb is bent, it may be straightened using needle-nose pliers. Be sure to remove all cardboard protecting panels and packing materials from the unit. A careful visual inspection should reveal any shipping damage such as bent or broken measuring tubing, damaged casing, etc. If shipping damage is evident, the unit must be repaired prior to placing it in service to avoid inaccurate signals. Please call Kele with any questions you may have.

MODEL IDENTIFICATION

The model and serial number of each KMS Airflow Metering Station is inscribed on the identification tag which is riveted to the casing adjacent to the instrument connections. The measuring area of the station (in square feet) is also engraved on the tag. The area information is necessary to establish actual CFM (cubic feet per minute) flow values since the output signals from the station will be FPM (Feet per minute) velocity measurement as indicated by a pressure in inches of water column (in w.c.). FPM equals CFM divided by the effective area in square feet.

INSTALLATION

KMS stations in sizes up to 18 inches may be readily installed by positioning them in the duct opening and bolting them securely in place. Take care not to damage the honeycomb when positioning the unit between the flanges of the duct. Orient the unit with the honeycomb section facing upstream. Check the flow direction arrow on the long side of the station. Install standard gaskets or apply sealant (suitable to the duct system) between the flanges to give a positive seal. Tighten the flange bolts securely, but do not over-tighten. Approximately 12 to 15 ft. lbs. torque is sufficient. Refer to the installation diagram on the next page for allowable distances from duct obstructions.

Larger stations may be lifted into position using a chain or cable sling placed around the perimeter of the station, or by attaching hooks or eyebolts to the flanges. Stations 60-inches or larger may require eyebolts installed in a center balanced area in the "top" of the unit. **Note that the "top" may be any side of the station, depending on the desired location of the instrument connections. The KMS station will function equally well regardless of the installation angle or the inclination of the duct.** If eyebolts are installed, care must be taken when drilling into the casing to avoid damage to the honeycomb or measuring assembly. The use of 3/8" eyebolts is suggested, with a 4" x 4" washer inside to evenly distribute lifting stress. After installation of the unit, the eyebolt may be left in place or removed and the hole plugged with short bolt, washer, and nut to prevent air leakage.

SAMPLE CALCULATIONS

Flow Rate: 2119 ft³/min = 1 m³/s
 Velocity: 196.9 ft/mn = 1 m/s
 Pressure: 1" WC = 249.1 Pa
 Area: 10.765 ft² = 1m

Formula: $V = 4004 \sqrt{\Delta P}$ $\Delta P = \left[\frac{V}{4004}\right]^2$ Where V is in units of fpm and
 ΔP is in units of "W.C.."

Formula: $V = 1.289 \sqrt{\Delta P}$ $\Delta P = \left[\frac{V}{1.289}\right]^2$ Where V is in units of m/s and
 ΔP is in units of Pa

EXAMPLE:

CFM = 4000 ft³/min (1.89 m³/s)
 Duct Size = 24" x 24" therefore effective area (see chart on page 4) is 3.67 ft² (0.340m²)
 Velocity = CFM/A_e = 4000/3.67 = 1090 ft/min (5.536 m/s)

$$\Delta P = \left[\frac{1090}{4004}\right]^2 = \left[\frac{1,188,100}{16,032,016}\right] = 0.0741 \text{ W.C. (18.5 Pa)}$$

An appropriate pressure transducer would be one with a range of 0-0.1 W.C. (24.91 Pa)
 A_e = Effective area.

INSTALLATION DIAGRAM

D = Duct diameter or the longest dimension of a rectangular duct.

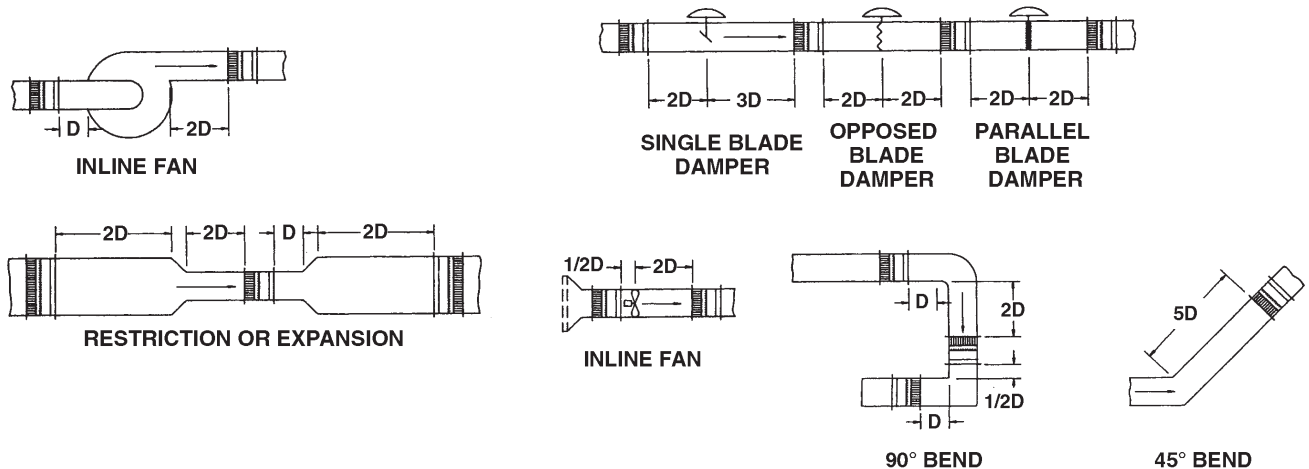

ORDERING INFORMATION

MODEL	DESCRIPTION
KMS	Airflow Measuring Station
	811 Round with Flanges
	911 Rectangular with Flanges
W x H	Diameter or Width x Height (in inches)

KMS - 911 - 48 x 24

Example: Rectangular airflow station with 16 gauge galvanized casing, 3/8" straightening vanes, and copper probes, 48" wide x 24" high.

T30, T40
 M264, M267
 UMM-1-SQ

Related Products
 Differential Pressure Transmitters
 Differential Pressure Transmitters
 Universal Math Module with Square Root Output

EFFECTIVE AREA OF KMS FLOW STATIONS

Note: Dimensions are in units of inches and areas are listed in units of ft²

		Width (inches)																																		
		4	6	8	10	12	14	16	18	20	22	24	26	28	30	32	34	36	38	40	42	44	46	48	50	52	54	56	58	60	62	64	66	68	70	
inches	mm	100	150	200	250	300	350	400	450	500	550	600	650	700	750	800	850	900	950	1000	1050	1100	1150	1200	1250	1300	1350	1400	1450	1500	1550	1600	1650	1700	1750	
4	100	0.10	0.15	0.19	0.24	0.29	0.34	0.39	0.44	0.49	0.53	0.58	0.63	0.68	0.73	0.78	0.83	0.88	0.92	0.97	1.02	1.07	1.12	1.17	1.22	1.26	1.31	1.36	1.41	1.46	1.51	1.56	1.60	1.65	1.70	
6	150		0.23	0.31	0.38	0.46	0.53	0.61	0.69	0.78	0.84	0.92	0.99	1.07	1.115	1.27	1.30	1.38	1.45	1.53	1.60	1.68	1.76	1.83	1.91	2.06	2.14	2.14	2.22	2.29	2.37	2.44	4.52	2.60	2.67	
8	200			0.39	0.49	0.58	0.68	0.78	0.88	0.97	1.07	1.17	1.26	1.36	1.46	1.56	1.65	1.75	1.85	1.94	2.04	2.14	2.24	2.33	2.43	2.53	2.63	2.72	2.82	2.92	3.01	3.11	3.21	3.31	3.40	
10	250				0.63	0.75	0.88	1.00	1.13	1.25	1.38	1.50	1.63	1.75	1.88	2.00	2.13	2.25	2.38	2.50	2.63	2.75	2.88	3.00	3.13	3.25	3.38	3.50	3.63	3.75	3.88	4.00	4.13	4.25	4.38	
12	300					0.92	1.07	1.22	1.38	1.53	1.68	1.83	1.99	2.14	2.29	2.44	2.60	2.75	2.90	3.06	3.21	3.36	3.51	3.67	3.82	3.97	4.13	4.28	4.43	4.58	4.74	4.89	5.04	5.19	5.35	
14	350						1.22	1.39	1.56	1.74	1.91	2.08	2.26	2.43	2.60	2.78	2.95	3.13	3.30	3.47	3.65	3.82	3.99	4.17	4.34	4.51	4.69	4.88	5.03	5.21	5.38	5.56	5.73	5.90	6.08	
16	400							1.61	1.81	2.01	2.22	2.42	2.62	2.82	3.02	3.22	3.42	3.63	3.83	4.03	4.23	4.43	4.63	4.83	5.03	5.24	5.44	5.64	5.84	6.04	6.24	6.44	6.65	6.85	7.05	
18	450								2.06	2.29	2.52	2.75	2.98	3.21	3.44	3.67	3.90	4.13	4.35	4.58	4.81	5.04	5.27	5.50	5.73	6.69	6.19	6.42	6.65	6.88	7.10	7.33	7.56	7.79	8.02	
20	500									2.50	2.75	3.00	3.25	3.50	3.75	4.00	4.25	4.50	4.75	5.00	5.25	5.50	5.75	6.00	6.25	6.50	6.75	7.00	7.25	7.50	7.75	8.00	8.25	8.50	8.75	
22	550										3.06	3.33	3.61	3.89	4.17	4.44	4.72	5.00	5.28	5.56	5.83	6.11	6.39	6.67	6.94	7.22	7.50	7.78	8.06	8.33	8.61	8.89	9.17	9.44	9.72	
24	600											3.67	3.97	4.28	4.58	4.89	5.19	5.50	5.81	6.11	6.42	6.72	7.03	7.33	7.64	7.94	8.25	8.56	8.86	9.17	9.47	9.78	10.08	10.39	10.69	
26	650												4.24	4.57	4.90	5.22	5.55	5.88	6.20	6.53	6.85	7.18	7.51	7.83	8.16	8.49	8.81	9.14	9.47	9.79	10.12	10.44	10.77	11.10	11.42	
28	700													4.96	5.31	5.69	6.02	6.38	6.73	7.08	7.44	7.79	8.15	8.50	8.85	9.21	9.56	9.92	10.27	10.63	10.98	11.33	11.69	12.04	12.40	
30	750														5.73	6.11	6.49	6.88	7.26	7.64	8.02	8.40	8.78	9.17	9.55	9.93	10.31	10.69	11.08	11.46	11.84	12.22	12.60	12.99	13.37	
32	800															6.44	6.85	7.25	7.65	8.06	8.46	8.86	9.26	9.67	10.07	10.47	10.88	11.28	11.68	12.06	12.49	12.89	13.29	13.69	14.10	
34	850																7.32	7.75	8.18	8.61	9.04	9.47	9.90	10.33	10.76	11.19	11.63	12.06	12.49	12.92	13.35	13.78	14.12	14.64	15.07	
36	900																	8.25	8.71	9.17	9.63	10.08	10.54	11.00	11.46	11.92	12.38	12.83	13.28	13.75	14.21	14.67	15.13	15.58	16.04	
38	950																		9.10	9.58	10.06	10.54	11.02	11.50	11.98	12.46	12.94	13.42	13.90	14.38	14.85	15.33	15.81	16.29	16.77	
40	1000																			10.14	10.65	11.15	11.66	12.17	12.67	13.18	13.69	14.19	14.70	15.21	15.72	16.22	16.73	17.24	17.74	
42	1050																				11.23	11.76	12.30	12.83	13.37	13.90	14.44	14.97	15.51	16.04	16.58	17.11	17.65	18.18	18.72	
44	1100																					12.22	12.78	13.33	13.89	14.44	15.00	15.56	16.11	16.67	17.22	17.78	18.33	18.89	19.44	
46	1150																						13.42	14.00	14.58	15.17	15.75	16.33	16.92	17.50	18.08	18.67	19.25	19.83	20.42	
48	1200																							14.67	15.28	15.89	16.50	17.11	17.72	18.33	18.94	19.56	20.17	20.78	21.39	
50	1250																								15.80	16.43	17.06	17.69	18.33	18.99	19.59	20.22	20.85	21.49	22.12	
52	1300																										17.15	17.81	18.47	19.13	19.79	20.45	21.11	21.77	22.43	23.09
54	1350																											18.56	19.25	19.94	20.63	21.31	22.00	22.69	23.38	24.06
56	1400																												19.83	20.54	21.25	21.96	22.67	23.38	24.08	24.79
58	1450																													21.35	22.08	22.82	23.56	24.29	25.03	25.76
60	1500																													22.92	23.68	24.44	25.21	25.97	26.74	
62	1550																																			
64	1600																																			
66	1650																																			
68	1700																																			
70	1750																																			

Note: For sizes not shown consult Kele.