



# Andover Continuum™

## CX 9702 SiteController for Small Buildings

Designed for small buildings, the CX 9702 SiteController provides networked, electronic access control, temperature control, and alarm monitoring in a single, cost-effective controller. A fully stand-alone device, the CX has two reader inputs and two lock outputs for door control; monitors four supervised alarm contacts and four universal alarm inputs; and includes two digital outputs for additional control of HVAC equipment, lighting and/or emergency annunciations. Power for locks, readers, and other peripherals is provided by the controller. Through its on-board Infinet field bus, the system can be expanded to include additional alarm monitoring and control with up to four stand-alone Infinet controllers.

- Single, Economical Solution for Small, Unmanned, or Remote Sites, Providing:
  - Alarm Monitoring
  - Access Control
  - Temperature Control
- Power and UPS Provided for Locks, Readers, Peripherals — Saves Installation Time
- Native TCP/IP Communications for Easy Network Connectivity
- Monitor Temperature, Humidity, Fire, Power with Universal Inputs
- SNMP Compatible — Allows Alarms to be Sent to Third-Party Network Management Systems
- Supports web.Client™, Andover Continuum's Web-Based User Interface
- Expansion via Andover Continuum's Infinet Distributed Controllers
- Total Point Count:
  - 8 Inputs
  - 2 Reader Inputs
  - 4 Outputs

The CX 9702 forms part of an integrated an Andover Continuum Security Management System, and is monitored and controlled through Andover Continuum CyberStation™ operator workstations, or Andover's web-based companion, web.Client™. Through dynamic, graphical displays, users can analyze system alarms and live conditions, and can unlock doors, and change setpoints, alarm thresholds, and operating modes instantaneously. Card access records can be edited, privileges granted, and event history analyzed to maintain the highest levels of security. An interface to digital video recording is easily accomplished so that any alarm seen by the CX 9702 will cause the correct camera to pop-up to the operator, and to record the event for future call-up.

### COMMUNICATIONS

The CX has an on-board Ethernet 10/100base-T interface, using native TCP/IP protocol to communicate to one or more Andover Continuum CyberStations. In addition, the CX has SNMP management built-in, so that alarms can be sent directly from the controller to any industry-standard network management software package.

The CX 9702 supports web.Client, Andover Continuum's web-based user interface, allowing authorized users access to the system from anywhere on the network.

When a high-speed network is not available, a standard auto-dial modem may be connected to the CX 9702 for cost-effective communications.

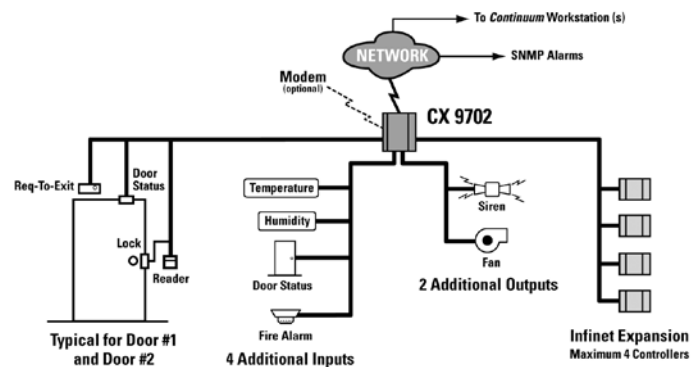

Typical Small Access Control and Integrated Facility System

## FLASH MEMORY

The CX features flash memory. Flash memory allows you to download software revisions over using an Andover Continuum workstation, and eliminates the need to perform EPROM changeouts in the field.

## INPUTS/OUTPUTS

The Andover Continuum CX 9702 has a full complement of inputs and outputs for two controlled doors, plus two digital outputs and four universal inputs.

Each door is controlled through a card reader input, capable of reading either Wiegand Swipe or Proximity card readers, or ABA mag stripe readers. Keypads are also usable on the same inputs. A door switch input and request-to-exit input, plus a door strike relay output round out each door's I/O. Power is provided for readers, locks, and auxiliary devices, reducing installation costs. Unused door switch and request-to-exit inputs may be used as general-purpose digital or supervised inputs. Unused door outputs may be used as general-purpose digital outputs.

In addition to door control, the CX has four universal inputs, capable of monitoring most any analog, digital or supervised signal. Common applications include temperature and humidity monitoring, fire alarm interface, cabinet tamper alarm, and power alarms. Two digital relay outputs, each with a manual override switch, provide means to control lights, air conditioning, or special interlocks or override sequences as needed.

## SOFTWARE OPERATION

Each CX 9702 manages its own personnel records, alarm and event buffering, history logging, and control sequences. If communication is lost to the central station, the CX buffers alarms and events, and then automatically uploads the alarms and events when communication is restored. Besides card records and events, the dynamic memory of the CX can be allocated for any combination of programs, schedules, reporting, and data logging using the Andover Plain English™ programming language. With its intuitive keywords, Plain English provides an easy method to tailor the controller to meet your exact requirements.

## UPS OPERATION

The Andover Continuum CX 9702 incorporates software programmable battery back-up that reduces or eliminates the impact of power failures. When main power is lost, the CX supports full operation for up to one hour. If desired, the CX can be automatically switched, through software, to low-power mode, whereby the battery powers the SDRAM and real-time clock for up to 7 days.

## DIMENSIONAL DRAWINGS

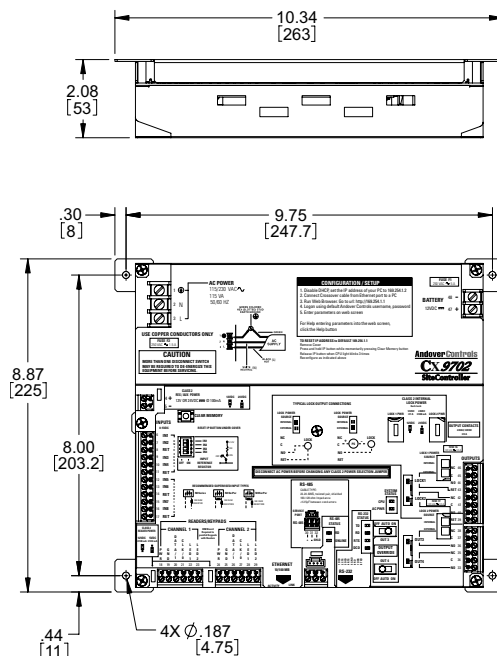

# SPECIFICATIONS

## CMX 9702 SiteController for Small Buildings

### ELECTRICAL

#### Power:

115/230VAC, 50/60 Hz, 115VA consumption

#### Peripheral Power:

30W, 5V/12V/24V (included in consumption total), for readers and locks

#### Overload Protection:

Fused with 1.5A 3AG fuse, 1500 volt transformer isolation. MOV protected

#### Real Time Clock:

Battery-backed by UPS

### MECHANICAL

#### Operating Environment:

32° F to 120°F (0° to 49°C), 10 to 95% RH (non-condensing)

#### Size, Weight:

Open class: 8.9"H x 10.3"W x 2.1"D (225H x 262W x 53D) mm; 2.0 lbs (.96 kg)

Small enclosure: 14"H x 15"W x 3.25"D (356H x 381W x 82D) mm; 11.0 lbs (6.09 kg)

Medium enclosure: 16"H x 22"W x 3.25"D (406H x 559W x 82D) mm; 16.0 lbs (8.35 kg)

#### Enclosure Type:

Open class; small or medium-size locked NEMA 1 enclosure with tamper switch available

### BATTERY, UPS

#### Battery Backup Operation:

Full Operation for 1 hour (typical), can be programmed to switch to CPU operation only (5 hours), or memory and clock backup only (7 days) using TACs battery-P/N: 01-2100-423. Expandable by use of greater amp-hour batteries

#### Batteries:

Qty 1, 12V / 7.0 AHr lead-acid battery (included with enclosure bundles)

#### Battery Charging Circuit:

Included in power supply, 3 days deep discharge recovery time, fused

### INPUTS

#### Card Reader Inputs: 2

#### Card Reader Type:

Supports Wiegand swipe and proximity readers, and keypads that support the Wiegand 8-bit burst format. Also supports ABA mag stripe readers.

#### Maximum Number of Bits per Card:

256

#### Card Reader Power:

5 V @ 120mA, 12V @ 180 mA, fused, jumper-selectable per controller

#### Distance, Card Reader to Controller:

500 ft. max. using 18-ga. wire; 200 ft. max. using 22-ga. wire

#### Door Switch Inputs:

2, single or double resistor supervision. Usable as general-purpose digital inputs

#### Request-to-Exit Inputs:

2, single or double resistor supervision. Usable as general-purpose digital inputs

#### Request-to-Exit Power:

12V @100mA, 24V @ 100mA, fused, jumper-selectable

#### Universal Inputs:

4; each may be configured as a Voltage, Thermistor, Digital, Counter, or Supervised input

#### Voltage:

Range: 0–5V  
Resolution: 5 mV  
Accuracy: ±15 mV (±0.3% FSR)

#### Thermistor:

Type: 10 KW, Type III Thermistor  
Range: -30 to 230°F (-34 to 110°C)  
Resolution: 40 to 100°F (4 to 38°C) range; 0.20°F (0.11°C) typical  
Accuracy: 40 to 100°F (4 to 38°C) range; ± 1.0°F (±0.55°C)

#### Digital & Counter:

Input Type: Contact Closure  
Frequency: 4 Hz (max.)  
Pulse Width: 125 ms ( min.) (Digital pulse widths are based on Scan Time.)

#### Supervised:

Input Type: Single or Double Resistor Supervision, Parallel or Series Circuit

### OUTPUTS

#### Door Strike Relay Outputs:

2 Form C relays, no override switches. Usable as general-purpose digital outputs

#### Door Strike Power:

12V @ 1A, 24V @ 300 mA per output, fused, jumper-selectable per controller. Power can be interrupted by removing a jumper

#### Output Indication:

LED's

#### Digital Relay Outputs:

2 Form C relays, with local override switches

#### Relay Contact Rating:

3A@24VAC; 3A@30VDC

# SPECIFICATIONS

(Continued)

## COMMUNICATIONS

### Ethernet LAN Interface:

10/100 Ethernet twisted pair, RJ-45

### Ethernet Distance:

327 feet (100m) standard between 2 nodes using 10/100 base-T unshielded twisted pair cable. Standard Ethernet repeaters allow for longer distances

### Serial Comm. Interface:

Port 1: RS-485 Infinet, maximum of 4 nodes. Includes service port.

Port 2: RS-232: Modem, printer, Plain English™ software interface (modem or printer provided by others). (No terminal interface)

### Serial Comm. Speed:

300 to 19.2K baud selectable

### Infinet Bus (optional):

4,000 feet (1,220m) standard for Infinet using approved shielded, twisted pair, low capacitance cable. Infilink module allows extension to longer distances. 4 Infinet nodes maximum

### SNMP:

Standard: Node system information.

Optional: alarm information via SNMP Trap. Supports MIB level I and II.

CX system information, alarms via SNMP TRAPs or direct polling, plus MIB II data

## CONNECTIONS

### Power:

Power: 3-position barrier strip

### Ethernet:

RJ-45 connector for Ethernet 10/100 base-T

### Infinet, Inputs, Outputs:

Removable terminal strips

### User Terminal, Modem:

RJ-45 connector

## GENERAL

### Microprocessor:

Motorola Coldfire, 32-bit, 66 MHz

### Memory:

SDRAM: 32MB; FLASH: 4MB

### Storage:

290,000 Card Records, with 2,000 Events

### Software Compatibility:

CyberStation 1.53 or greater

## AGENCY LISTINGS

UL/CUL 916, FCC CFR 47 Part 15, EN55022, AS/NZS 3548, VCCI Class A, CE, Enclosure: UL 916 and CSA, C22.2. No. 205-M198

Copyright © 2006, TAC  
All brand names, trademarks and registered trademarks are the property of their respective owners. Information contained within this document is subject to change without notice.  
All rights reserved.

SDS-C-9702BLDG-US  
05/06



www.tac.com

