



- Powerful, Flexible Local Controller for the Most Demanding Applications
- Non-Volatile Flash Memory Provides Utmost Reliability — Stores Both Application Program and Operating System
- Local, Extended Storage of Log Data
- View and Modify Information with Optional Smart Sensor Display
- Local, On-Board Service Port

# Infinet II

## i2800 Series Local Controllers

The i2800 series are designed for control of small Air Handling Units, Unit/Roof Top, and other mechanical plant equipment. Choose the i2800 series controller with the configuration that matches your application:

- The i2800, designed for stand-alone equipment control of Roof Top or Air Handling Units, features eight Universal Inputs, one Smart Sensor/Room Sensor input, plus eight program-controlled Digital Outputs.
- The i2804, designed for stand-alone equipment control of Roof Top or Air Handling Units, features eight Universal Inputs, one Smart Sensor/Room Sensor input, plus four program-controlled Digital Outputs and four Analog Outputs for direct control of devices requiring 0-10 volt control signals.  
Note: The i2804 is compatible with Continuum™ (only).

Both models feature an additional room sensor input, which supports Andover Continuum Smart Sensor, or any standard room temperature sensor.

The i2800 series also features Flash memory, increased user memory, and a fast (32-bit) processor for faster scan times, with plenty of memory available for data logging of your critical data.

The i2800 communicates with the entire Andover Infinet™ RS-485 field bus; i.e., both Infinet™ and Infinet II controllers, and is compatible with both the Continuum CyberStation™ and Infinity™ SX 8000 front-ends. Up to 254 Infinet devices can be networked to any Andover Continuum network controller.

### INCREASED RELIABILITY WITH FLASH MEMORY

The i2800's non-volatile Flash memory stores your operating system and application programs, so that in the event of a power loss, your application will be restored when power is returned. In addition, the Flash memory allows for easy upgrades of your operating system via software downloads, eliminating the need to swap out proms. The i2800 controllers include an on-board battery to safeguard your runtime data — protecting all point data and log data from being lost if power is removed.

# i2800 Series Local Controllers

## INPUTS

The input configuration on the i2800 series consists of eight full range, 10-bit Universal inputs that accept voltage (0-5VDC), digital (on/off), counter signals (up to 4Hz), temperature signals, or supervised alarm circuits for security applications or broken wire detection. The i2800 series offers an additional input to support the Andover Smart Sensor, or any standard room temperature sensor.

## OUTPUTS

The i2800 contains eight Form C relay outputs, each rated for 24 VAC/VDC, 3 amp, while the i2804 contains four Form C relay outputs and four analog outputs (0-10V).

## SOFTWARE CAPABILITIES

The dynamic memory of the i2800 can be allocated for any combination of programs, scheduling, alarming, and data logging using the powerful Andover Plain English™ programming language. Our object-oriented Plain English language with intuitive keywords provides an easy method to tailor the controller to meet your exact requirements. Programs are entered into the i2800 using the Continuum CyberStation™. Programs are then stored and executed by the i2800 controllers.

Programming multiple i2800 series controllers is inherently easy with Plain English. A complete copy of one i2800's programs can be loaded directly into other i2800s without changing any point names or programs.

## SMART SENSOR INTERFACE

The i2800 provides a built-in connection for Andover Continuum's Smart Sensor. The Smart Sensor provides a 2-character LED display and a 6-button programmable keypad that enables operators and occupants to change setpoints, balance VAV boxes, monitor occupancy status, and turn equipment on and off. An enhanced version of the Smart Sensor is also available with a 4-digit custom LCD that provides the following icons: PM, %, °, Setpoint, Cool, Heat, CFM, Fan, OA, and SP.

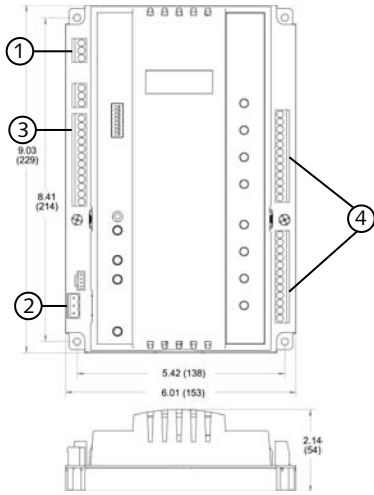

Dimensional Drawing

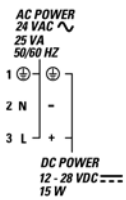

① Power Drawing

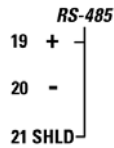

② Communications Drawing

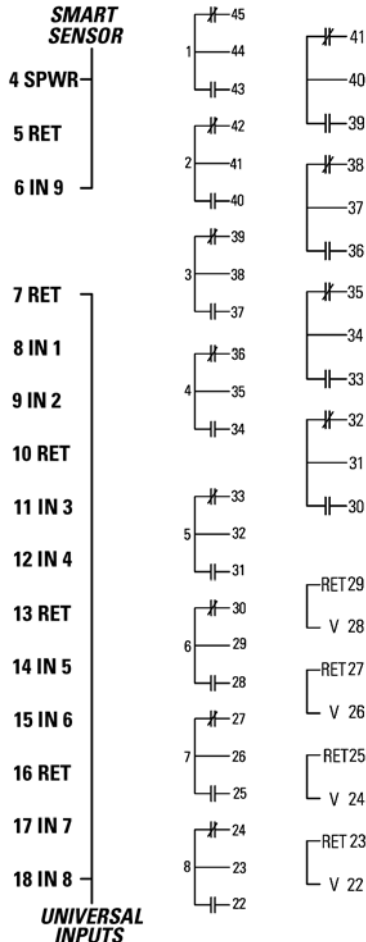

③ Smart Sensor Drawing ④ i2800 i2804 Inputs

# SPECIFICATIONS

## i2800 Series Local Controllers

### ELECTRICAL

#### Power

24VAC, 12-24VDC - auto sensing,  
+10% -15%, 50/60 Hz

#### Power Consumption

25 VA

#### Overload Protection

Fused with 3 amp fuse. MOV protected

#### Software Real-Time Clock

Synchronized through Infinet by  
network controller

### MECHANICAL

#### Operating Environment

-10°-140°F (-23-60°C), 10-95% RH  
(non-condensing)

#### Size

9.03" H x 6.01" W x 2.14" D  
(229 H x 153 W x 54 D) mm

#### Weight

1.34 lbs. (0.61 kg)

#### Enclosure Type

UL Open class, IP 10. Flammability  
rating of UL94-5V

#### Mounting

Panel mount

### BATTERY

#### Battery Backup

Replaceable, non-rechargeable, lithium  
battery. Provides 5 years typical accu-  
mulated power failure backup of RAM  
memory

### COMMUNICATIONS

#### Communications Interface

Through Infinet RS-485 field bus to  
network controller

#### Communications Speed

1200 to 19.2K baud

#### Bus Length

4,000 ft. (1,220m) standard for Infinet,  
I2 Infilink module allows extension to  
longer distances and is required after  
every group of 32 units on the network.

#### Bus Media

Infinet: twisted, shielded pair, low  
capacitance cable

#### Comm. Error Checking

International Standard CRC 16

### Compatibility

Continuum CyberStation and Infinity  
SX 8000 systems

Note: The i2804 is compatible with  
Continuum (only).

### INPUTS/OUTPUTS

#### INPUTS

8 Universal inputs: Voltage (0-5.115  
VDC); Temperature -30°F to 230°F  
(-34°C to 110°C), Digital (on/off),  
Counter (up to 4Hz at 50% duty cycle,  
125 ms min. pulse width). Supervised  
Alarm (single or double resistor). Cur-  
rent input (0 - 20 mA) using external  
250 ohm resistor.

1 Smart Sensor Temperature Input  
(32°F to 105°F) (0°C to 41°C)

Input Voltage Range  
0-5.115 volts DC

Input Impedance  
10K ohm to 5.120V or 5M ohm  
with pull-up resistor disabled

Input Resolution  
5.0 mV

Input Accuracy  
±15mV (±0.56°C from -23°C to  
+66°C or ±1°F from -10°F to +150°F)

#### DIGITAL OUTPUTS

8 single pole single throw (SPST)  
Form C relays (4 Form C on i2804)  
(Any two consecutive Form C outputs  
can be configured as one Form K  
Tri-state)

Output Rating  
Maximum 3A, 24VAC/VDC,  
±1500V transients (Tested  
according to EN61000-4-4)

Output Accuracy  
0.1 sec. for pulse width modulation

#### ANALOG OUTPUTS

4 analog outputs (i2804 only)

Output Rating  
For 0-10V: 5mA maximum, 2K  
ohm minimum impedance, ±1000V  
transients (Tested according to  
EN61000-4-4)

Output Resolution  
0.1V for 0-10V

### CONNECTIONS

#### Power

3-position fixed screw terminal  
connector

#### Inputs

12-position fixed screw terminal  
connector

#### Outputs

i2800: 2- 12-position fixed screw termi-  
nal connector i2804: 1-12-position fixed  
screw terminal connector and 1- 8-posi-  
tion fixed screw terminal connector

#### Smart Sensor

3-position fixed screw terminal  
connector

#### Communications

3-position removable screw terminal  
connector

#### Service Port

4-position shrouded connector

### USER LEDS/SWITCHES

#### Status Indicator LEDS:

CPU	CPU Active
TD	Transmit Data
RD	Receive Data
Output	Output Status (per output) (Digital only)

#### Switches

RESET  
Input Pull-up Resistor Switch (per input)

### GENERAL

#### Memory

128K SRAM, 1MB FLASH

#### Processor

Motorola 32-bit Coldfire

### AGENCY LISTINGS

UL/CUL 916, FCC CFR 47 Part 15,  
ICES-003, EN55022, AS/NZS 3548,  
Class A, CE

### OPTIONS

UL864, Smoke Control System  
Equipment, UUKL (i2800-S, i2804-S)

---

Copyright © 2006, TAC  
All brand names, trademarks and registered trademarks are  
the property of their respective owners. Information contained  
within this document is subject to change without notice.  
All rights reserved.

SDS-I2800-US  
1/06



[www.tac.com](http://www.tac.com)

