

CD60 LOW LEAKAGE CONTROL DAMPER High Performance Airfoil

STANDARD CONSTRUCTION

FRAME

5" x 1" x 16 gage (127 x 25 x 1.6) galvanized steel hat channel reinforced with corner braces for structural strength equal to 11 gage (3.05) channel frames. Low profile 3 1/2" x 3/8" x 16 gage (89 x 10 x 1.6) galvanized steel channel top and bottom frame on dampers under 12" (305) high.

BLADES

Galvanized steel airfoil shaped, double skin construction of 14 gage (2.0) equivalent thickness, 6" (152) wide. Parallel or opposed action.

SEALS

Ruskiprene blade edge seals and flexible metal compressible jamb seals.

BEARINGS

Stainless steel sleeve.

LINKAGE

Concealed in frame.

AXLES

1/2" (13) plated steel hex.

CONTROL SHAFT

6" (152) x 1/2" (13) diameter - removable. Outboard shaft support bracket supplied with all single section dampers for field mounted actuators. Factory-installed jackshaft supplied with all multiple section dampers.

FINISH

Mill.

MAXIMUM SIZE

Single section - 60"w x 72"h (1524 x 1829).
Multiple section assembly - Unlimited size.

MINIMUM SIZE

Single blade - 8"w x 6"h (203 x 152).
Two blades, parallel or opposed action: 8"w x 10"h (203 x 254).

TEMPERATURE LIMITS

-72°F (-60°C) minimum and +275°F (+135°C) maximum.

NOTE: Dimensions shown in parenthesis () indicate millimeters.

*Units furnished approximately 1/4" (6) smaller than given opening dimensions.

†Jackshaft used only on multiple section dampers.

Ruskin Company certifies that the CD60 shown herein is licensed to bear the AMCA Seal. The ratings shown are based on tests and procedures performed in accordance with AMCA Publication 511 and comply with the requirements of the AMCA Certified Ratings Program. The AMCA International Certified Ratings Seal applies to Air Performance and Air Leakage.



FEATURES

- The CD60 offers sturdy, steel construction with interlocking frame design. Damper locks together without bolts, screws, or rivets that could shake loose. Frame corners are internally braced to reduce racking.
- Axles positively lock to blades without screws or welds. Non-stick, noncorrosive bearings assure long life and ease of operation. Axles and bearings combine with a shake proof linkage for low maintenance operation.
- Airfoil blade design and linkage concealed in the frame out of the air stream to reduce turbulence for low pressure drop and noise generation.
- Ruskiprene blade edge seals mechanically locked into the blade for superior low leakage in the closed position.
- Airfoil design allows for use in systems up to 12" w.g. maximum total static pressure.

VARIATIONS

Variations to the CD60 basic design are available at additional cost. They include:

- Factory-installed, pneumatic and electric actuators (specific information required with order).
- Enamel and epoxy finishes.
- Ruskin frame-mounted universal actuator bracket to simplify field installation of most actuators (specify actuator and action, i.e., N.O. or N.C., with order).
- SP100 Switch Package to remotely indicate damper blade position.
- Heavier frame construction with U-channel frame.
- Front, rear or double flange frame with or without bolt holes.

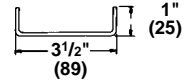
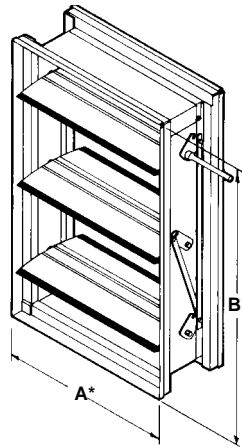

Heavy Construction/
Special Materials
U-channel Frame Option

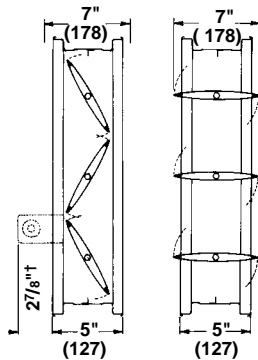

OPPOSED BLADE PARALLEL BLADE

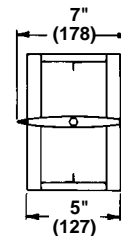

Low profile frame
illustrated is typical for
units under 12" (305) high.

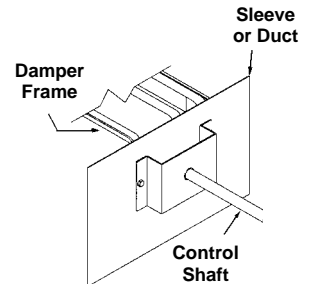

Outboard Shaft
Support Bracket

QTY.	OPENING DIM.		BLADE ACTION		FRAME STYLE			ACTUATOR P - Pneu. E - Elec.	VARIATIONS
	A*	B*	PB	OB	STD.	Front Flange FF	Rear Flange RF		

JOB
CONTRACTOR

LOCATION

CD60 PERFORMANCE DATA

CD60 PRESSURE LIMITATIONS

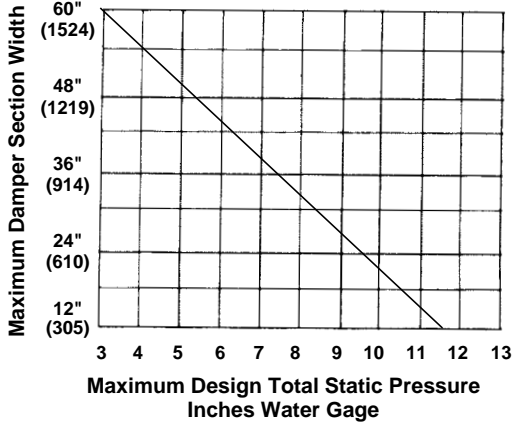

The CD60 may be used in systems with total pressures exceeding 3.5" by reducing damper section width as indicated. Example: Maximum design total pressure of 8.5" w.g. would require CD60 damper with maximum section width of 36" (914).

Pressure limitations shown above allow maximum blade deflection of 1/180 of span on 60" (1524) damper widths. Deflections in other damper widths (less than 48" [1219]) at higher pressures shown will result in blade deflection substantially less than 1/180 of span.



Ruskin Company certifies that the CD60 shown herein is licensed to bear the AMCA Seal. The ratings shown are based on tests and procedures performed in accordance with AMCA Publication 511 and comply with the requirements of the AMCA Certified Ratings Program. The AMCA International Certified Ratings Seal applies to Air Performance and Air Leakage.

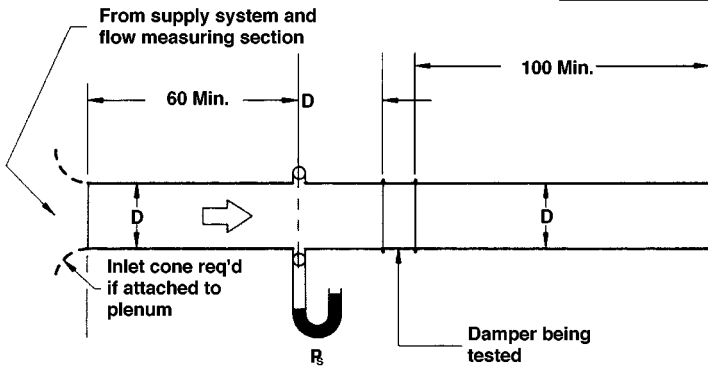

AMCA STANDARD 500
FIGURE 5.3 DAMPER TEST SETUP WITH INLET AND OUTLET DUCTS

DAMPER WIDTH (INCHES)	1 IN. W.G.	4 IN. W.G.	8 IN. W.G.
12" (305)	I	I	II
24" (610)	I	I	II
36" (914)	I	I	NA
48" (1219)	I	I	NA
60" (1524)	I	I	NA

VELOCITY VS. PRESSURE DROP

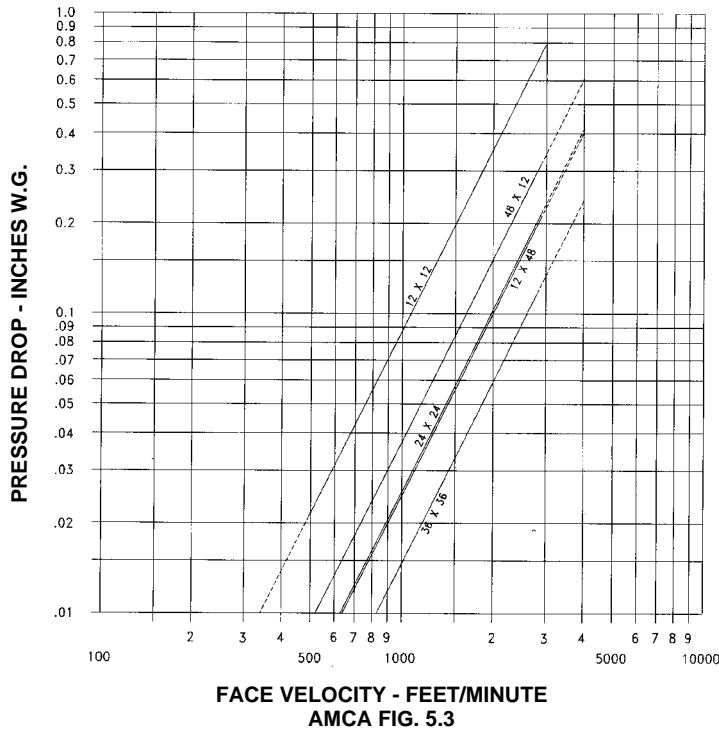

CD60 sizes 12 x 12, 24 x 24, 48 x 12, 12 x 48, 36 x 36
(305 x 305, 610 x 610, 1219 x 305, 305 x 1219, 914 x 914)

All data corrected to represent standard air at a density of 0.075 lbs/ft³.

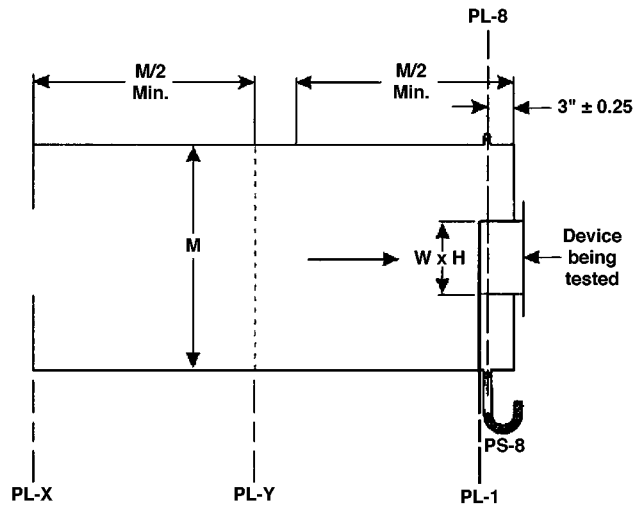

ALTERNATE MOUNT B (LEAKAGE TEST ONLY)
FIGURE 5.5 TEST DEVICE SETUP WITH INLET CHAMBER

Class I =
4 CFM Sq. Ft. @ 1" w.g.;
8 CFM Sq. Ft. @ 4" w.g.;
11 CFM Sq. Ft. @ 8" w.g.

Class II =
10 CFM Sq. Ft. @ 1" w.g.;
20 CFM Sq. Ft. @ 4" w.g.;
28 CFM Sq. Ft. @ 8" w.g.

Leakage testing conducted in accordance with AMCA Standard 500-D-98. Torque applied holding damper closed, 5 in. lbs./sq. ft. on opposed blade dampers and 7 in. lbs./sq. ft. on parallel blade dampers. Air leakage is based on operation between 50°F to 104°F. All data corrected to represent standard air density 0.075 lbs/ft³.

CD60 SUGGESTED SPECIFICATION

Furnish and install, at locations shown on plans, or in accordance with schedules, control dampers that meet the following minimum construction standards. Frame shall be 16 gage (1.6) galvanized steel structural hat channel with tabbed corners for reinforcement for 11 gage (3.05) structural equivalence. Blades shall be 14 gage (2.0) equivalent thickness galvanized steel, roll-formed airfoil type for low pressure drop and low noise generation. Blade edge seals shall be Ruskiprene type or equivalent suitable for -81°F (-63°C) to +302°F (+150°C) mechanically locked into the blade edge. Adhesive or clip-on type seals are unacceptable. Jamb seals shall be flexible metal, compression type to prevent leakage between blade end and damper frame. Blade end overlapping frame is unacceptable.

Bearings shall be corrosion resistant, permanently lubricated stainless steel sleeve type turning in an extruded hole in the damper frame. Axles shall be square or hexagonal positively locked into the damper blade. Linkage shall be concealed out of airstream, within the damper frame to reduce pressure drop and noise. Submittal must include leakage, maximum air flow and maximum pressure

ratings based on AMCA Publication 500. Damper shall be tested and certified in accordance with AMCA 511 for Air Performance and Air Leakage. Damper widths from 12" to 60" wide shall not leak any greater than 8 cfm sq. ft. @ 4" w.g. Dampers shall be in all respects equivalent to Ruskin Model CD60.

Specifier Select Options.

SP100: Dampers shall be equipped with factory installed damper position indication switch package. The switch package shall include two position indication switches linked directly to the damper blade to provide full open and full closed damper blade position. The switch package shall be capable of interfacing with the HVAC control system and provide remote damper blade position status. Switch package shall be in all respects equivalent to Ruskin Model SP-100.

Factory Mounted Damper Actuators: If control damper actuators are required, they shall be furnished and mounted by the damper manufacturer in their factory (or furnished to the damper manufacturer for factory installation). Each damper shall be cycle tested at the factory prior to shipment.

CD60 PERFORMANCE DATA

The actual pressure drop through a damper is the result of many factors. The formula and area factor table below may be used to estimate pressure drop for a CD60 of a given size, with straight duct runs upstream and downstream, as in AMCA Figure 5.3.

CD60 FREE AREA

Height Dim. B	Dimension A – Width In Inches													
	8" (203)	12" (305)	16" (406)	20" (508)	24" (610)	28" (711)	32" (813)	36" (914)	40" (1016)	44" (1118)	48" (1219)	52" (1321)	56" (1422)	60" (1524)
8" (203)	0.17	0.29	0.42	0.54	0.67	0.79	0.92	1.04	1.17	1.29	1.42	1.54	1.67	1.79
10" (254)	0.22	0.37	0.53	0.69	0.85	1.01	1.17	1.33	1.49	1.65	1.81	1.97	2.13	2.29
12" (305)	0.29	0.51	0.72	0.94	1.15	1.37	1.58	1.80	2.01	2.23	2.44	2.66	2.87	3.09
14" (356)	0.33	0.57	0.81	1.06	1.30	1.54	1.79	2.03	2.27	2.51	2.76	3.00	3.24	3.49
16" (406)	0.40	0.70	1.00	1.30	1.60	1.89	2.19	2.49	2.79	3.09	3.39	3.69	3.99	4.28
18" (457)	0.45	0.78	1.12	1.45	1.78	2.12	2.45	2.78	3.12	3.45	3.78	4.12	4.45	4.78
20" (508)	0.52	0.91	1.30	1.69	2.08	2.47	2.86	3.25	3.63	4.02	4.41	4.80	5.19	5.58
24" (610)	0.66	1.12	1.60	2.08	2.56	3.04	3.52	4.00	4.48	4.96	5.44	5.92	6.39	6.87
28" (711)	0.77	1.34	1.90	2.47	3.04	3.61	4.18	4.75	5.32	5.89	6.46	7.03	7.60	8.17
32" (813)	0.91	1.60	2.28	2.96	3.64	4.32	5.00	5.68	6.36	7.04	7.72	8.40	9.08	9.76
36" (914)	1.04	1.81	2.58	3.35	4.12	4.89	5.66	6.43	7.20	7.97	8.74	9.52	10.29	11.06
40" (1016)	1.16	2.02	2.88	3.74	4.60	5.46	6.32	7.19	8.05	8.91	9.77	10.63	11.49	12.35
44" (1118)	1.31	2.28	3.25	4.22	5.20	6.17	7.14	8.11	9.08	10.06	11.03	12.00	12.97	13.95
48" (1219)	1.43	2.49	3.55	4.62	5.68	6.74	7.80	8.87	9.93	10.99	12.05	13.12	14.18	15.24
52" (1321)	1.55	2.70	3.86	5.01	6.16	7.31	8.47	9.62	10.77	11.92	13.08	14.23	15.38	16.54
56" (1422)	1.70	2.96	4.23	5.49	6.75	8.02	9.28	10.55	11.81	13.07	14.34	15.60	16.87	18.13
60" (1524)	1.82	3.17	4.53	5.88	7.24	8.59	9.95	11.30	12.65	14.01	15.36	16.72	18.07	19.42
64" (1626)	1.94	3.39	4.83	6.27	7.72	9.16	10.61	12.05	13.50	14.94	16.39	17.83	19.27	20.72
68" (1727)	2.09	3.64	5.20	6.76	8.31	9.69	11.42	12.98	14.54	16.09	17.65	19.20	20.76	22.31
72" (1829)	2.21	3.86	5.50	7.15	8.80	10.44	12.09	13.73	15.38	17.02	18.67	20.32	21.96	23.61

Formula

$$\Delta P = 1.45 \left[\frac{\text{CFM}}{\text{Area Factor}} - \text{Vel.} \right]^2$$

ΔP = Pressure drop in inches w.g.
 Vel. = Duct Velocity in feet per minute
 CFM = Duct area in sq. ft. x velocity in FPM

INSTALLATION/MULTIPLE SECTIONS

INSTALLATION

CD60 IS NOT RECOMMENDED FOR INSTALLATION WITH BLADES RUNNING VERTICALLY.

If vertical blade application required, thrust collars and special construction necessary. Consult factory.

For proper installation, damper must be installed square and free from racking. Actuator must be installed on linkage side. Opposed blade dampers must be operated from a power blade or shaft. See "Induct Mount Control Dampers Installation Instructions" for details.

BRACING OF MULTIPLE SECTION DAMPER ASSEMBLIES

The CD60 is intended to be self supporting only in its largest single section size. Multiple section damper assemblies may require bracing to support the weight of the assembly and to hold against system pressure. Ruskin recommends appropriate bracing to support the damper horizontally at least once for every 8' of damper width. Vertical assemblies and higher system pressures may require more bracing.

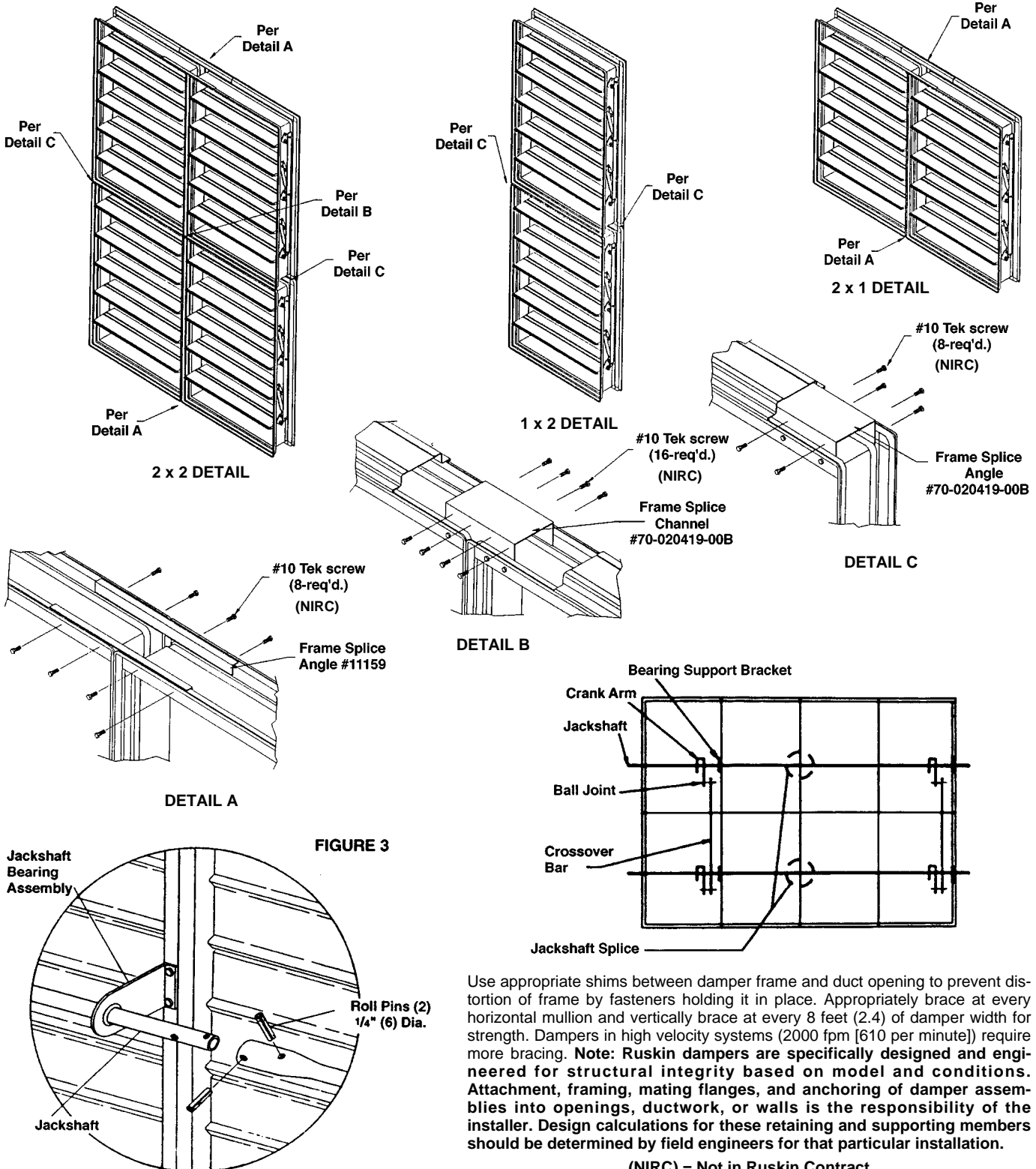

FIGURE 3

Use appropriate shims between damper frame and duct opening to prevent distortion of frame by fasteners holding it in place. Appropriately brace at every horizontal mullion and vertically brace at every 8 feet (2.4) of damper width for strength. Dampers in high velocity systems (2000 fpm [610 per minute]) require more bracing. **Note: Ruskin dampers are specifically designed and engineered for structural integrity based on model and conditions. Attachment, framing, mating flanges, and anchoring of damper assemblies into openings, ductwork, or walls is the responsibility of the installer. Design calculations for these retaining and supporting members should be determined by field engineers for that particular installation.**

(NIRC) = Not in Ruskin Contract