

# TAC Erie™ Zone Valves Two-Way Spring Return

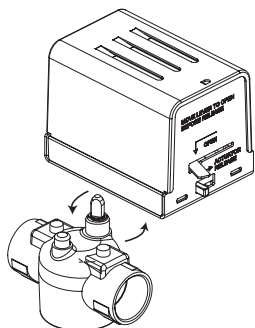

1/2 to 1 in. Female NPT Ends

**Two-Way Spring Return  
General Close-Off  
Two-Position**

<b>Flow Type</b>	On, off, normally open or closed
<b>Material</b>	<p><b>Body</b> Forged brass</p> <p><b>Seat</b> Brass</p> <p><b>Stem</b> Nickel plated brass</p> <p><b>Paddle</b> Highly saturated nitrile (VS), Buna N (VT)</p>
<b>Fluid Temperature</b>	<p>VT Series: 32 to 200 °F @ 104 °F ambient (0 to 93 °C @ 40 °C) Water</p> <p>VS Series: 32 to 250 °F @ 169 °F ambient (0 to 121 °C @ 76 °C) Water or 15 psi Steam</p>
<b>Maximum Static Pressure</b>	300 psi (20.6 bar))
<b>Seat Leakage</b>	ANSI IV

Size in.	Cv (K <sub>vs</sub> )	Close Off Pressure psi (kPa)	Normally Open/Normally Closed	VT Series 32 to 200 °F		VS Series 32 to 250 °F	
				24 Vac	120 Vac	24 Vac	120 Vac
1/2	1 (0.8)	60 (413)	NC	VT2221G13A020	VT2221G13B020	VS2221G14A020	VS2221G14B020
			NO	VT2221G23A020	VT2221G23B020	VS2221G24A020	VS2221G24B020
	2.5 (2.2)	40 (275)	NC	VT2222G13A020	VT2222G13B020	VS2222G14A020	VS2222G14B020
			NO	VT2222G23A020	VT2222G23B020	VS2222G24A020	VS2222G24B020
	3.5 (3)	25 (172)	NC	VT2223G13A020	VT2223G13B020	VS2223G14A020	VS2223G14B020
			NO	VT2223G23A020	VT2223G23B020	VS2223G24A020	VS2223G24B020
3/4	2.5 (2.2)	40 (275)	NC	VT2322G13A020	VT2322G13B020	VS2322G14A020	VS2322G14B020
			NO	VT2322G23A020	VT2322G23B020	VS2322G24A020	VS2322G24B020
	3.5 (3)	25 (172)	NC	VT2323G13A020	VT2323G13B020	VS2323G14A020	VS2323G14B020
			NO	VT2323G23A020	VT2323G23B020	VS2323G24A020	VS2323G24B020
	5 (4.3)	20 (138)	NC	VT2325G13A020	VT2325G13B020	VS2325G14A020	VS2325G14B020
			NO	VT2325G23A020	VT2325G23B020	VS2325G24A020	VS2325G24B020
	7.5 (6.5)	17 (117)	NC	VT2327G13A020	VT2327G13B020	VS2327G14A020	VS2327G14B020
			NO	VT2327G23A020	VT2327G23B020	VS2327G24A020	VS2327G24B020
1	8 (6.9)	20 (138)	NC	VT2427G13A020	VT2427G13B020	VS2427G14A020	VS2427G14B020
			NO	VT2427G23A020	VT2427G23B020	VS2427G24A020	VS2427G24B020

Zone Valves

**Actuator Code Table.**

Actuator Model (Reference pages 146 thru 148)	Description	Wiring Diagrams		Dimension Information	
		Page	Figure	Page	Figure
AG13A020, AG23A020 AG14A020, AG24A020	2-Position	152	1	206	102
AG13B020, AG23B020 AG14B020, AG24B020	2-Position	152	1	206	102

# TAC Erie™ AG, AH Series Spring Return Actuator Two-Position

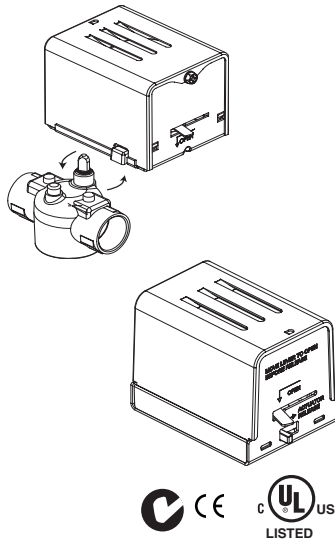

**Connections:** 18 in. leads.  
**Housing:** NEMA 1.  
**Dimensions:** G Series: 2-3/8 H x 2-3/8 W x 3-11/16 D in. (60 x 60 x 96 mm)  
 H Series: 2-7/16 H x 2-5/8 W x 3-11/16 D in. (62 x 67 x 93 mm)  
**Override:** Manual (normally closed models only).  
**Motor Type:** Hysteresis synchronous.  
**General Instructions:** Refer to F-26496.  
**Agency Listing:**

UL-873. Underwriters Laboratories (File #E9429 Category Temperature Indicating and Regulating Equipment).  
 European Community: EMC Directive (89/336/EEC). Low Voltage Directive (72/23/EEC).  
 CUL: UL listed for use in Canada by Underwriters Laboratory. Canadian Standards C22.2 No. 24.  
 Australia: This product meets requirements to bear the C-Tick Mark according to the terms specified by the Communications Authority under the Radio Communications Act of 1992.

Zone Valves

General Close-Off, 2-Position, Power (Open or Close): 9 to 11 Seconds; Spring Return (Open or Close): 4 to 5 Seconds						
Model No.	Volts AC	VA	Electrical Position	Temperature Range F (C)	End Of Travel Switch	Wiring
AG13A020	24	7.5	Normally Closed	32 to 200°F (Fluid) @ 104°F (Ambient) (0 to 93°C @ 40°C)	No	18 in. (45.7 cm) Leads
AG13B020	120			32 to 250°F (Fluid) @ 169°F (Ambient) (0 to 121°C @ 76°C)		
AG14A020	24					
AG14B020	120					
AG23A020	24		Normally Open (can only be used on 2-way valve)	32 to 200°F (Fluid) @ 104°F (Ambient) (0 to 93°C @ 40°C)		
AG24A020	24			32 to 250°F (Fluid) @ 169°F (Ambient) (0 to 121°C @ 76°C)		
AG23B020	120			32 to 200°F (Fluid) @ 104°F (Ambient) (0 to 93°C @ 40°C)		
AG24B020	120			32 to 250°F (Fluid) @ 169°F (Ambient) (0 to 121°C @ 76°C)		

High Close Off, 2-Position, Power (Open or Close): 13 to 18 Seconds; Spring Return (Open or Close): 4 to 5 Seconds						
Model No.	Volts AC	VA	Electrical Position	Temperature Range F (C)	End Of Travel Switch	Wiring
AH13A020	24	7.5	Normally Closed	32 to 200°F (Fluid) @ 104°F (Ambient) (0 to 93°C @ 40°C)	No	18 in. (45.7 cm) Leads
AH13B020	120			32 to 250°F (Fluid) @ 169°F (Ambient) (0 to 121°C @ 76°C)		
AH14A020	24					
AH14B020	120					
AH23A020	24		Normally Open (can only be used on 2-way valve)	32 to 200°F (Fluid) @ 104°F (Ambient) (0 to 93°C @ 40°C)		
AH23B020	120			32 to 250°F (Fluid) @ 169°F (Ambient) (0 to 121°C @ 76°C)		
AH24A020	24					
AH24B020	120					

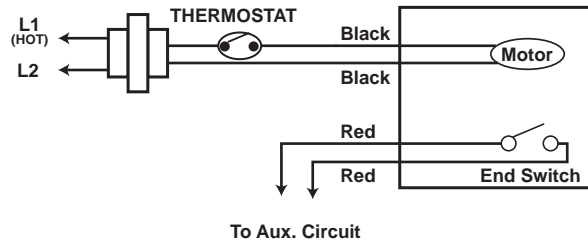

**Figure 1 AG/AH TAC Erie PopTop with Wire Leads.**

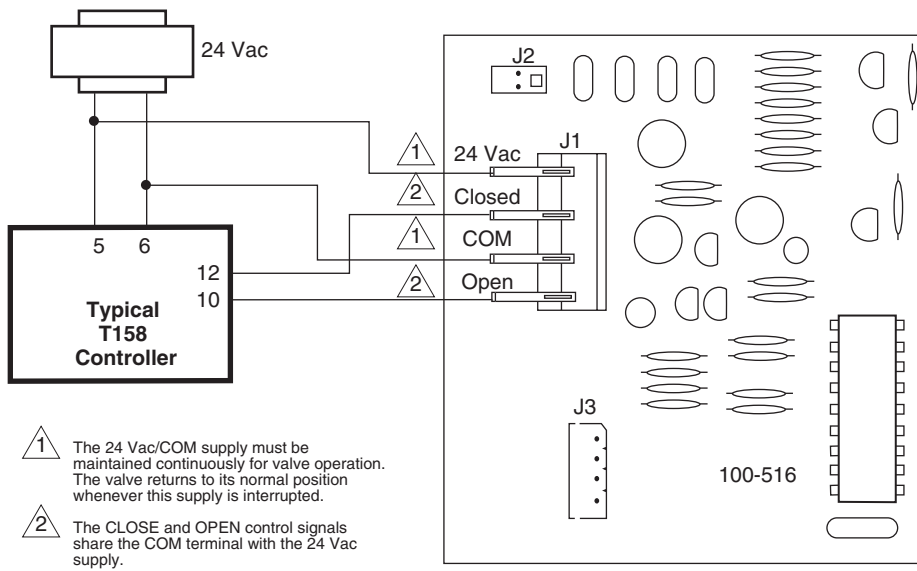

**Figure 2 ATx3A00T TAC Erie PopTop 3-Wire Floating Actuator with Time-Out.**

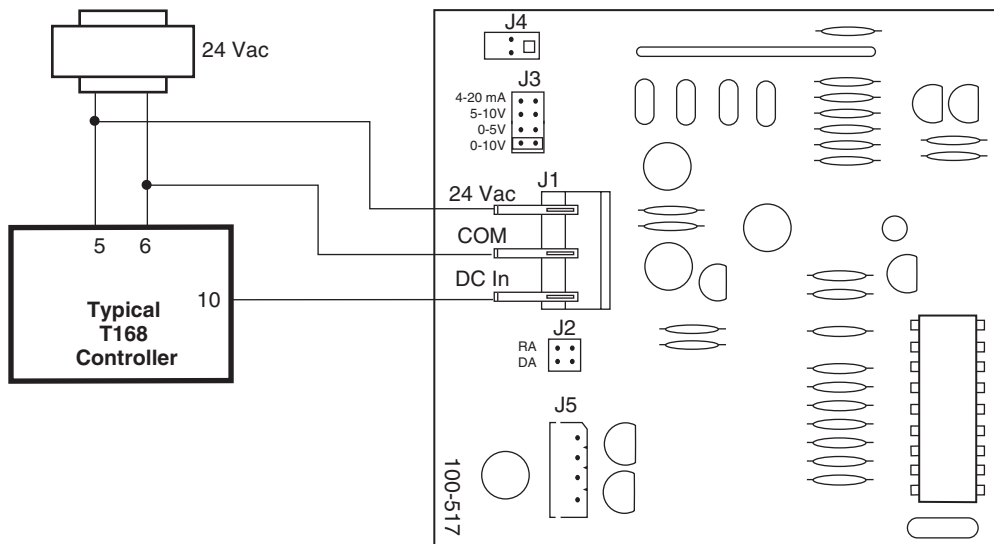

**Figure 3 APx3A000 TAC Erie PopTop Three-Wire Proportional Actuator.**

**Dimensions — 1/2" to 1" Zone Valve Assemblies**

Valve Body Size inches	Valve Dimensions in inches (millimeters)				
	A	B 2-Way	C 3-Way	D (General Close-Off) (Refer to Figure 102)	D (High Close-off) (Refer to Figure 103)
1/2" Sweat	1-5/16 (33)	15/16 (23)	1-5/16 (33)	3-5/16 (84)	3-5/8 (92)
3/4" Sweat	1-3/8 (35)	15/16 (23)	1-11/16 (43)	3-3/8 (86)	3-3/4 (95)
1" Sweat	1-11/16 (43)	15/16 (23)	1-11/16 (43)	3-5/8 (92)	4 (102)
1-1/4" Sweat	1-7/8 (47)	1 (25)	1-13/16 (46)	3-11/16 (94)	4-1/8 (105)
1/2" NPT	1-3/8 (35)	15/16 (23)	1-5/16 (33)	3-3/8 (86)	3-3/4 (95)
3/4" NPT	1-11/16 (43)	15/16 (23)	1-7/16 (37)	3-5/8 (92)	4 (102)
1" NPT	1-7/8 (47)	1 (25)	1-11/16 (43)	3-11/16 (94)	4-1/8 (105)

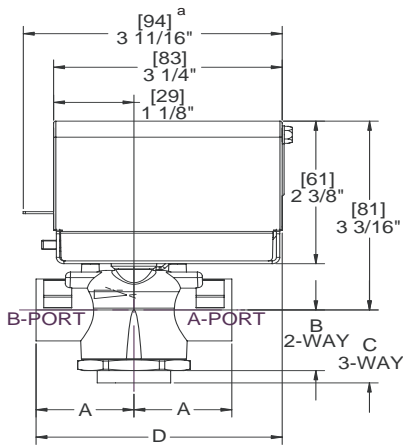

<sup>a</sup> Normally closed model only.

**Figure 102 VT/VS AG Series General Close-Off.**

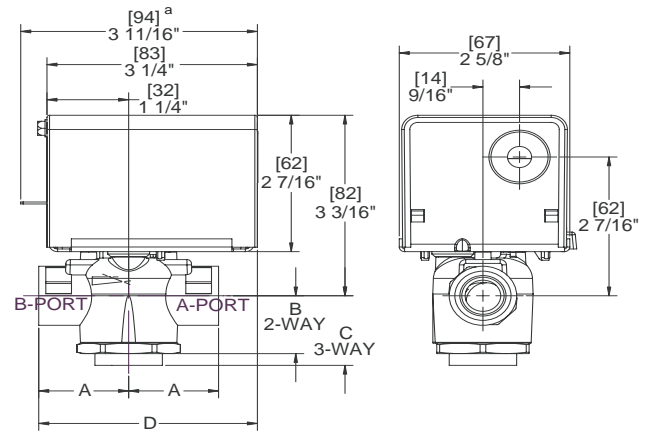

<sup>a</sup> Normally closed model only.

**Figure 103 VT/VS AH Series High Close-Off.**