



SPECIALTY SENSORS

MULTIGAS REFRIGERANT MONITOR MODEL HGM-SZ

DESCRIPTION

The **Model HGM-SZ** is a single refrigerant gas monitor for low-level continuous monitoring of CFC, HCFC, and HFC refrigerant gases used in most commercial refrigeration systems. The design supports compliance to the refrigerant monitoring requirements of ANSI/BSR ASHRAE 15-1994/2001.

FEATURES

- 24 different refrigerants monitored with one unit
- Infrared, nondispersive detection
- Three adjustable SPDT alarm contacts
- System fault alarm
- 120/240 VAC power
- 4-20 mA output signal
- 50-foot sampling tube and end filter included
- Audible alarm
- Backlit LED display with navigation keys
- Local alarm-silence button
- Water trap included



SPECIALTY SENSORS

SPECIFICATIONS

| | |
|----------------------------|--|
| Power | 100/120/240 VAC, 50/60 Hz |
| Detector type | Single pass, infrared non-dispersive |
| System gas library | R11, R12, R113, R114, R502, R404a, R407a, R407c, R134a, R410a, R507, R508b, R22, R123, R124, R500, R503, R401a, R402a, R408a, R409a, R23, 1301 |
| Output | 3 alarm relays, 1 fault relay 240 VAC, 5A, and 4-20 mA 500Ω (non-isolated) |
| Sensitivity | 1 ppm |
| Measuring range | 0-10,000 ppm |
| Accuracy | ±10 ppm (0-100 ppm) ±10% reading (100-1000 ppm) |
| Warm-up time | 15 min. |
| Response time | 12.2-22.5 sec |
| Monitoring distance | Up to 50' (15.2m) (sample tube and end filter included) |
| Operating temp | 32° to 122°F (0° to 50°C) |
| Humidity | 5% to 90% noncondensing |
| Dimensions | 12.37"H x 15"W x 3.5"D (19.3 x 38.1 x 8.9 cm), includes water trap and mounting flange |
| Weight | 7 lb (3.2 kg) |
| Calibration | Unit re-zeroes every 6 min., adjustment in software if needed |
| Certification | UL listed, CE approved |
| Warranty | Two years |

INSTALLATION

The **Model HGM-SZ** should be centrally located in the mechanical room and readily accessible for easy visual monitoring and servicing. The air sample tube may be run up to 50' (15.2m) from the monitor.

WIRING

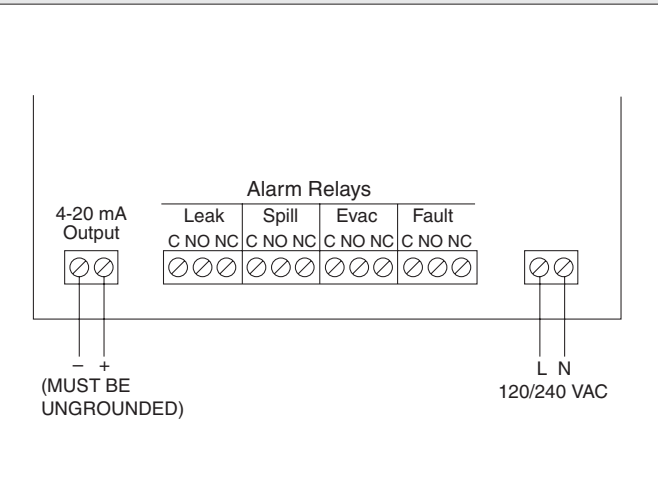

ORDERING INFORMATION

| MODEL | DESCRIPTION |
|----------|------------------------------|
| HGM-SZ | Multigas Refrigerant Monitor |
| 125-SS-2 | Replacement Charcoal Filter |
| M1104KF | Line End Filter |